



Modular Cooking Range Line 900XP Half Module Electric Fry Top, Chromium Plated

ITEM # _____

MODEL # _____

NAME # _____

SIS # _____

AIA # _____



391072 (E9FTEDCS00)

Half module electric fry top with smooth sloped chromed plate, thermostatic control

391175 (E9FTEDCS0N)

Electric fry top with smooth sloped chromed plate, thermostatic control

Short Form Specification

Item No. _____

Smooth cooking surface in chromium-plated mild steel. To be installed on open base installations, bridging supports or cantilever systems. Removable drawer below the cooking surface for the collection of grease and fat. Body and work top of unit entirely in stainless steel with Scotch Brite finish. Extra strength work top in heavy duty 2 mm stainless steel. Right-angled side edges to allow flush-fitting junction between units.

Main Features

- Unit to be mounted on open base cupboards, bridging supports or cantilever systems.
- Large drain hole on cooking surface permits the draining of fat into large 1 liter collector placed under the cooking surface.
- Electric elements in incoloy positioned under the cooking plate.
- Safety thermostat and thermostatic control.
- Stainless steel high splash guards on the rear and sides of cooking surface. Splash guards can be easily removed for cleaning and are dishwasher-safe.
- The special design of the control knob system guarantees against water infiltration.
- IPX5 water protection.
- Temperature range from 120° up to 280°C.
- Polished chromium surface avoids the mixing of flavors when passing from one type of food to another.
- Cooking surface 15mm thick polished chrome for optimum grilling results and ease of use.
- Suitable for countertop installation.

Construction

- Cooking surface completely smooth.
- Unit is 930 mm deep to give a larger working surface area.
- All exterior panels in Stainless Steel with Scotch Brite finishing.
- AISI 304 stainless steel worktop, 2mm thick.
- Model has right-angled side edges to allow flush fitting joints between units, eliminating gaps and possible dirt traps.

Included Accessories

- 1 of Scraper for smooth plate fry tops PNC 164255

Optional Accessories

- Scraper for smooth plate fry tops PNC 164255
- Junction sealing kit PNC 206086
- Support for bridge type installation, 800mm PNC 206137
- Support for bridge type installation, 1000mm PNC 206138
- Support for bridge type installation, 1200mm PNC 206139
- Support for bridge type installation, 1400mm PNC 206140
- Support for bridge type installation, 1600mm PNC 206141

APPROVAL: _____



- Water drain for half module fry tops PNC 206153
- Support for bridge type installation, 400mm PNC 206154
- Back handrail 800mm, Marine PNC 206308
- BACK HANDRAIL 1200 MM PNC 206309
- Grease/oil kit container for 700 line frytops (half and module) and 900 line frytops (module) PNC 206346
- Rear paneling - 1000mm (700/900) (only for 391072) PNC 206375
- Chimney grid net, 400mm (700XP/900) PNC 206400
- - NOT TRANSLATED - PNC 206455
- Side handrail-right/left hand (900XP) PNC 216044
- Frontal handrail, 400mm PNC 216046
- Frontal handrail, 800mm PNC 216047
- Frontal handrail, 1200mm PNC 216049
- Frontal handrail, 1600mm PNC 216050
- 2 side covering panels for free standing appliances (only for 391175) PNC 216134
- Large handrail - portioning shelf, 400mm PNC 216185
- Large handrail - portioning shelf, 800mm PNC 216186
- 2 side covering panels for top appliances PNC 216278
- ACC_CHEM**
- *NOT TRANSLATED* PNC 0S2292

Front

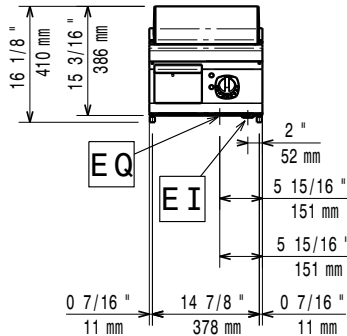

Side

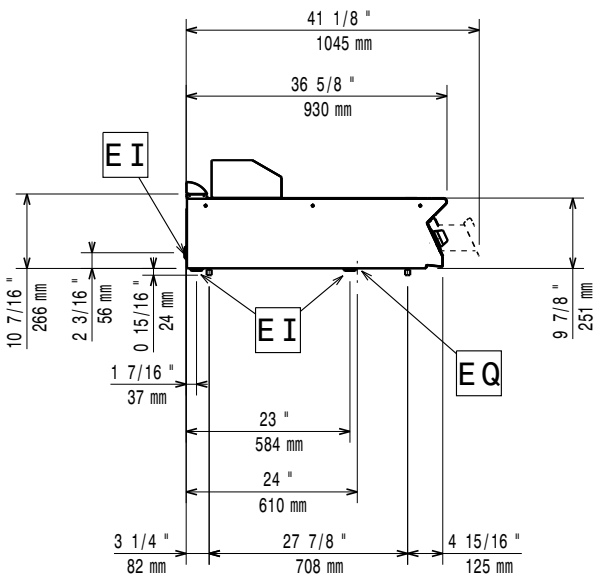

EI = Electrical inlet (power)
EQ = Equipotential screw

Top

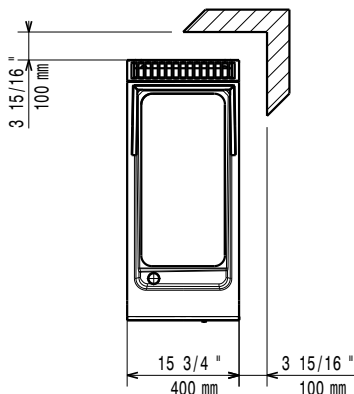

Electric

Supply voltage:

391072 (E9FTEDCS00)

380-400 V/3 ph/50-60 Hz

391175 (E9FTEDCS0N)

230 V/3 ph/50/60 Hz

Total Watts:

7.5 kW

Key Information:

Working Temperature MIN: 120 °C

Working Temperature MAX: 280 °C

External dimensions, Width: 400 mm

External dimensions, Depth: 930 mm

External dimensions, Height: 250 mm

Net weight: 55 kg

Shipping weight:

391072 (E9FTEDCS00)

56 kg

391175 (E9FTEDCS0N)

55 kg

Shipping height:

391072 (E9FTEDCS00)

580 mm

391175 (E9FTEDCS0N)

540 mm

Shipping width:

460 mm

Shipping depth:

1020 mm

Shipping volume:

391072 (E9FTEDCS00)

0.27 m³

391175 (E9FTEDCS0N)

0.25 m³

[NOT TRANSLATED]

391072 (E9FTEDCS00)

EFT9I

391175 (E9FTEDCS0N)

N9REI

Cooking surface width:

330 mm

Cooking surface depth:

700 mm

If appliance is set up or next to or against temperature sensitive furniture or similar, a safety gap of approximately 150 mm should be maintained or some form of heat insulation fitted.